

15 ZRT

| | | | | | | | | | | |
|---------------|-------------|-------------|-----------|------------------|------|--------|---------------|---------------------------|--------------------------|---------------------------|
| | | | | | | | | | | |
| 135 - 140 kNm | 5,5 - 9,9 m | 3,3 - 4,6 m | 3,8 - 5 m | 2.260 - 2.440 kg | 415° | 25 kNm | 255 - 285 bar | Minimum 100 l/min ~ 50 kW | Minimum 75 l/min ~ 79 kW | Minimum 170 l/min ~ 71 kW |

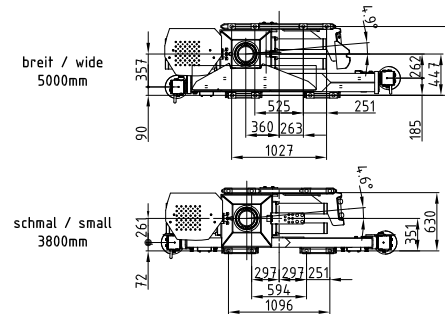

| | | | | | | | | |
|--|-----------|------|------|------|------|------|------|------|
| | 15ZT9.70R | 2560 | 2040 | 1680 | 1420 | 1240 | 1090 | (kg) |
| | 15ZT8.00R | 2700 | 2150 | 1790 | 1530 | 1240 | | (kg) |
| | | 4m | 5m | 6m | 7m | 8m | 9m | |

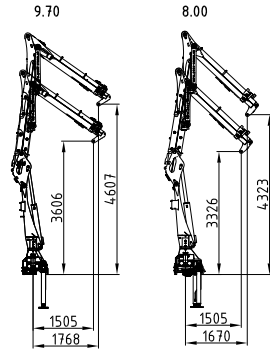
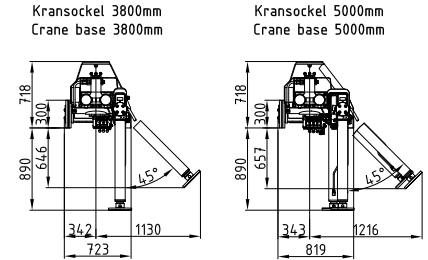
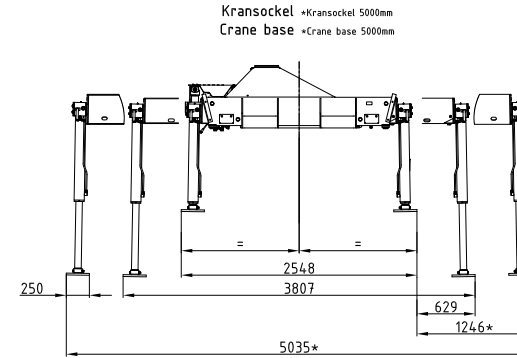
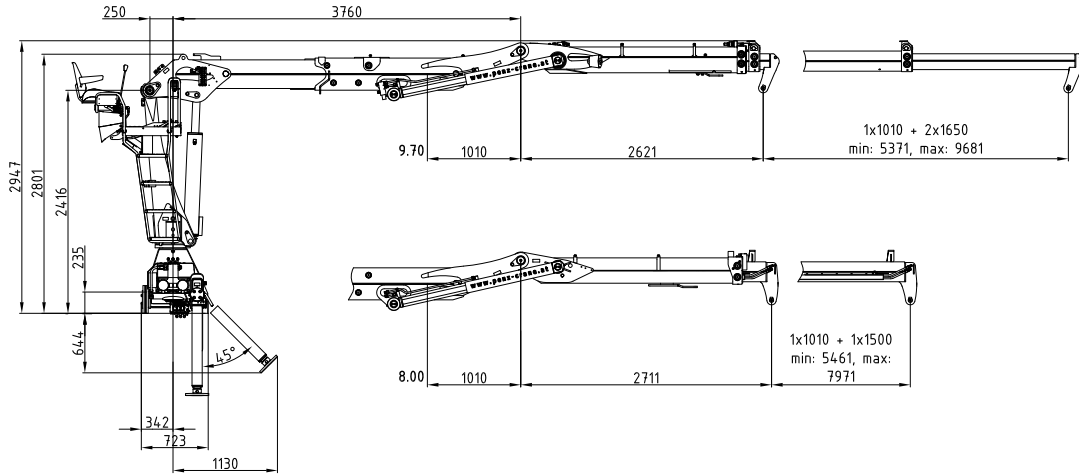